

C0330 - 300lb Cube Ice Machine

Prodigy Plus® Modular Cube Ice Machine

The world's smartest cuber.

As the world's only self-monitoring cuber, the new Scotsman Prodigy Plus cube ice machines make it easier than ever to maintain your equipment and save money. Whether it's the advanced ice level control or an optional feature board for quick diagnostics, this is ice-making re-imagined. And with intuitive technology like AutoAlert™ indicator lights, a reduced operational footprint and easy-access service from the front panel, Prodigy Plus® cubers are simply the smartest, most reliable way to create fresh-tasting ice — every time.

The Prodigy Plus difference.

- AutoAlert™ indicator lights for better visibility
- Operational footprint among the industry's smallest
- Industry-exclusive QR code instantly connects users to service information and warranty history
- One-touch cleaning reduces labor costs and saves time
- Front-located air filter for more efficient operation
- Self-aligning front panel for easy access to key components
- Patented WaterSense purge control automatically reduces scale buildup
- Patented Harvest Assist efficiently moves cube ice to the bin
- Smart-Board™ advanced feature module available for additional diagnostic capabilities
- Optional Vari-Smart™ ice level control allows operators to customize ice levels
- Antimicrobial protection guards internal surfaces between cleanings
- A full range of water- and energy-saving features



C0330 - 300lb Cube Ice Machine



24 Hour Volume Production

Air Cooled		Water Cooled	
70°F/21°C 50°F/10°C	Air Water	90°F/32°C 70°F/21°C	70°F/21°C 50°F/10°C
400/182 lb/kg		288/131 lb/kg	420/191 lb/kg
			326/148 lb/kg



Modular Bin Options

Model Number*	Dimensions W" x D" x H"	Bin Application		Ship Weight lb/kg
		Capacity lb/kg	Finish	
B330P	30 x 34 x 30**	344/156	Poly	130/59
B530S or P	30 x 34 x 44**	536/244	Metallic or Poly	132/60

* Contact Scotsman for bin top requirements. ** Add 6" Height for bin legs.



B330P



B530P



Cube Ice

Common ice form, ideal for mixed drinks.



Small Cube
7/8" x 7/8" x 3/8"
(2.22 x 2.22 x .95 cm)



Medium Cube
7/8" x 7/8" x 7/8"
(2.22 x 2.22 x 2.22 cm)



Certification



Warranty

- 3 years parts and labor on all components.
- 5 years parts and labor on the evaporator.
- 5 years parts on the compressor and condenser.
- Warranty valid in North, South & Central America for commercial installations.
- Contact factory for warranty in other regions.
- Residential Applications: 1 year parts and labor

C0330 - 300lb Cube Ice Machine

Prodigy Plus® Modular Cube Ice Machine

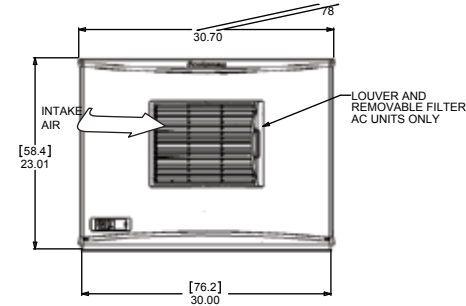
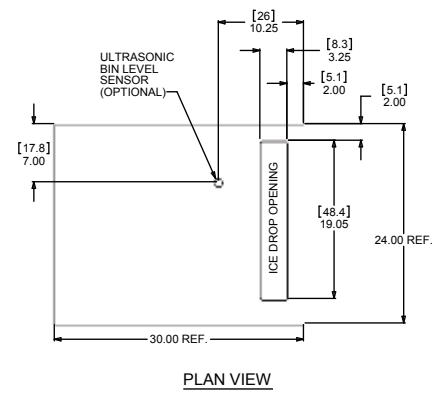
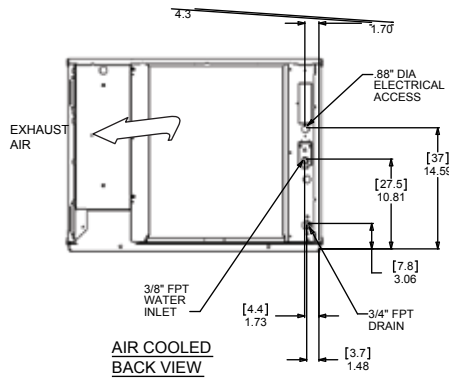
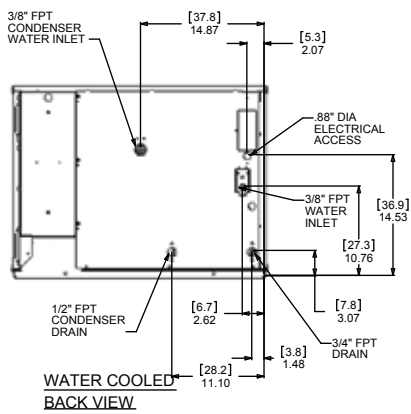

Specifications

Model Number	Condenser Unit	Basic Electrical Volts/Hz/Phase	Max. Fuse Size or HACR Circuit Breaker (amps)	Circuit Wires	Min. Circuit Ampacity	Energy Consumption kWh/100 lb (45.4 kg) 90°F(32°C)/70°F(21°C)	Water Usage Gallon s/100 lb (liters/45.4 kg)	
							Potable 90°F(32°C)/70°F(21°C)	Condenser 90°F(32°C)/70°F(21°C)
med. C0330 MA-1	Air	115/60/1	15	2	14.3	6.23	18.0/68.1	-
C0330MW-1	Water	115/60/1	15	2	13.5	4.97	18.0/68.1	139.0/526.2
C0330MA-32	Air	208-230/60/1	15	2	7.1	6.23	18.0/68.1	-
sm. C0330SA-1	Air	115/60/1	15	2	14.3	6.23	18.0/68.1	-
C0330S W-1	Water	115/60/1	15	2	13.5	4.97	18.0/68.1	139.0/526.2



All Models

Dimensions (W x D x H):

Unit: 30" x 24" x 23" (76.2 x 61.0 x 58.4 cm)

Shipping Carton: 33.5" x 27.5" x 28" (85.1 x 69.9 x 71.1 cm)

Shipping Weight: 155 lb / 70 kg

BTUs per hour: 5,200

Refrigerant: R-404A



Accessories

Model Number	Description
KVS	Vari-Smart™ Ice Level Control - Program ice bin levels to match ice needs.
KSBU	Smart-Board™ Advanced Control - Use additional operational data for fast diagnosis.
KSBU-N	Smart-Board™ Advanced Control with Network - Network capable.
KPAS	Prodigy Advanced Sustainability Kit - Includes KVS and KSBU - N
KPPSA323	Prodigy Plus™ Side Air Flow Kit for C0330, C0530 and C0630

Scotsman recommends all ice machines have water filtration. See Scotsman water filter specification sheet for details.



Operating Requirements

	Minimum	Maximum
Air Temperatures	50°F (10°C)	100°F (38°C)
Water Temperatures	40°F (4.4°C)	100°F (38°C)
Remote Cond. Temps	-20°F (-29°C)	120°F (49°C)
Water Pressures	20 PSIG (1.4 bar)	80 PSIG (5.5 bar)
Electrical Voltage	-5%	+10%

Specifications and design are subject to change without notice.

C0330 - 300lb Cube Ice Machine



PURE WATER TECHNOLOGY
OF THE GULF COAST