

Scotsman
UNDERCOUNTER UNITS

UC2024 - 200 lb Cube Ice Machine

Self-Contained Undercounter Ice Machine with Storage



Features and Benefits

Space Saving Design:

- Only 24" wide, this ice maker can be placed in the tightest locations
- Front breathing - No side clearance required for flexible placement
- Recessed utility chase provides clearance for tight installs
- Optional floor mount kit lowers height to 33.5"

Ease of Use:

- Removable external air filter for easy cleaning
- Unit specific QR code for quick access to service manuals, cleaning guides and warranty history
- Ergonomic slide back door allows easy access to ice in the bin
- Power cord, NEMA 5-15P plug, ice scoop and adjustable legs are included for quick and easy installation

Reliability:

- Heavy duty, rust-free front panel and corrosion-resistant aluminum alloy side panels for maximum lifespan
- 3 Year parts and labor warranty
- Designed, engineered and assembled in the USA

High Production:

- Produces up to 230 lb (104 kg) per day and stores 80 lb (36 kg), maximizing ice output despite its small footprint

Environmentally Friendly:

- Meets new US federal energy efficiency requirements
- Meets US Safe Drinking Act low lead requirements
- Non-ozone depleting R-134A refrigerant



Front accessible external air filter for easy cleaning



Recessed utility chase provides clearance for tight installs



Ergonomic slide-back door allows easy access to ice in the bin



Unit specific QR code for quick access to service manuals, cleaning guides and warranty history



24 Hour Volume Production

Air Cooled		Water Cooled	
70°F/21°C 50°F/10°C	Air Water	90°F/32°C 70°F/21°C	70°F/21°C 50°F/10°C
227/103 lb/kg		166/75 lb/kg	230/104 lb/kg
			176/80 lb/kg



Cube Ice

Common ice form, ideal for mixed drinks.



Small Cube
7/8" x 7/8" x 3/8"
(2.22 x 2.22 x .95 cm)



Medium Cube
7/8" x 7/8" x 7/8"
(2.22 x 2.22 x 2.22 cm)



Certification



Warranty

- 3 years parts and labor on all components
- 5 years parts on the compressor
- Warranty valid in North, South & Central America for commercial installations
- Contact factory for warranty in other regions
- Residential Applications: 1 year parts and labor



PURE WATER TECHNOLOGY
OF THE GULF COAST

UC2024 - 200 lb Self-Contained Ice Machine

UC2024 - 200 lb Cube Ice Machine

Self-Contained Undercounter Ice Machine with Storage

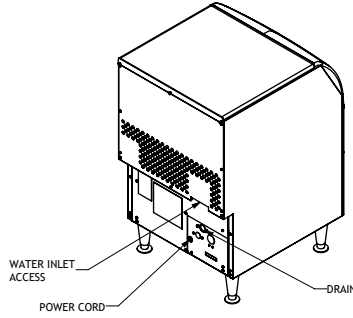
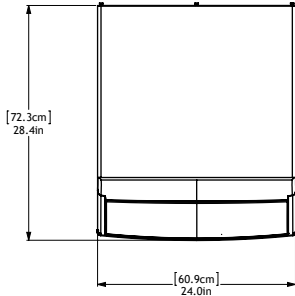

Front breathing and no side clearance required, allowing for flexible placement

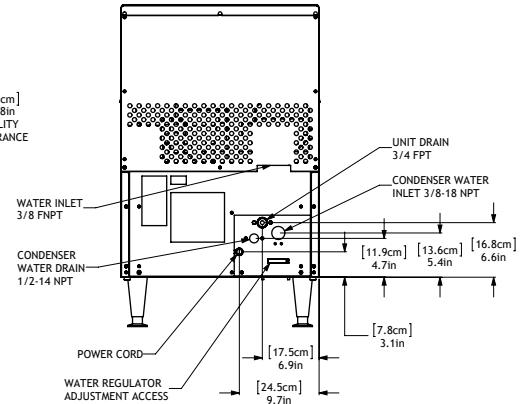
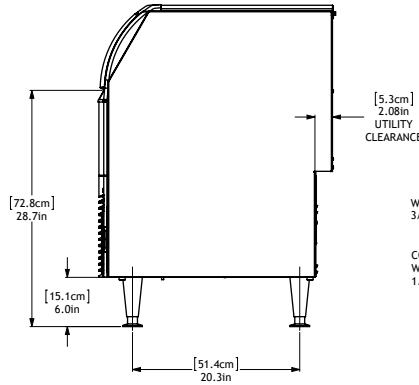
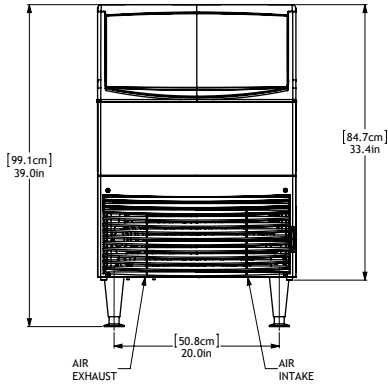

UC2024 - 200 lb Self-Contained Ice Machine



Specifications

Model Number <small>Cube Size: medium or small</small>	Condenser Unit	Storage Capacity lb/kg	Basic Electrical Volts/Hz/Phase	Max. Fuse Size or HACR Circuit Breaker (amps)	Circuit Wires	Min. Circuit Amperage	Energy Consumption kWh/100 lb (45.4 kg) 90°F(32°C)/70°F(21°C)	Water Usage Gallons/100 lb (liters/45.4 kg)		Energy Star®
								Potable 90°F(32°C)/70°F(21°C)	Condenser 90°F(32°C)/70°F(21°C)	
UC2024MA-1	Air	80/36	115/60/1	15	2	Cord	6.27	22.4/85.3	-	✓
UC2024MW-1	Water	80/36	115/60/1	15	2	Cord	4.91	21.8/83.0	111/422.7	
UC2024SA-1	Air	80/36	115/60/1	15	2	Cord	6.27	22.4/85.3	-	✓
UC2024SW-1	Water	80/36	115/60/1	15	2	Cord	4.91	21.8/83.0	111/422.7	



All Models

Dimensions (W x D x H):

Unit: 24" X 28.5" X 39"
(61.0 x 72.4 x 99.1 cm)

Height includes 6" (15.24 cm) adjustable legs

Shipping Carton: 29" x 39" x 39"
(73.7 x 99.1 x 99.1 cm)

Shipping Weight: 150 lb / 68 kg

BTUs per hour: 3,900

Refrigerant: R-134A



Accessories

Model Number	Description
KLP8S	Kit, Leg 6", Stainless Steel
KBC1	Kit, Casters
KUFM24	Floor mount kit. Lowers height to 33.5"

Scotsman recommends all ice machines have water filtration. See Scotsman water filter specification sheet for details.



Operating Requirements

	Minimum	Maximum
Air Temperatures	50°F (10°C)	100°F (38°C)
Water Temperatures	40°F (4.4°C)	100°F (38°C)
Water Pressures	20 PSIG (1.4 bar)	80 PSIG (5.5 bar)
Electrical Voltage	-5%	+10%

Specifications and design are subject to change without notice.



PURE WATER TECHNOLOGY
OF THE GULF COAST